

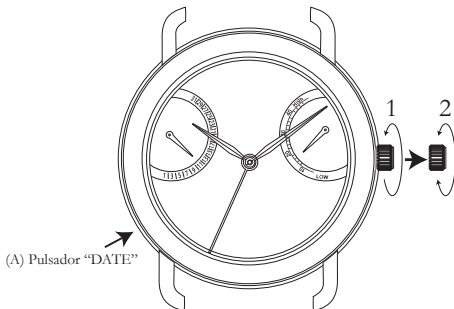

COLOMER & SONS
SPAIN

USER INSTRUCTIONS



1.Start:

Being an automatic watch we suggest you wind it up completely the first time you use it (Position 1) The crown will need to be wound manually 15 – 20 times to develop a sufficient power reserve to ensure the accuracy of the timepiece. You do not have to repeat this action every day while the watch is in use, the watch will charge itself automatically

2. Setting of the time:

Pull out the crown (Position 2) and move the hands to the desired time.

3. Adjusting the date:

There are 2 ways of doing this: By pressing the pusher (A) situated on the inferior external left side of the watch, or when adjusting the time every 24 hours by moving the hands (Position 2). This calendar has a “Flyback” system incorporated which returns the hand automatically on the last date of the month. If the month has fewer days, it must be adjusted manually.

Note:

* The date changes somewhere between 0:00 am and 5:30 a.m. hours or a little later.

4. Power Reserve indicator:

This system indicates the power of the movement left in case you remove the watch from your wrist. Fully charged, the power reserve lasts approximately 42 hours.